

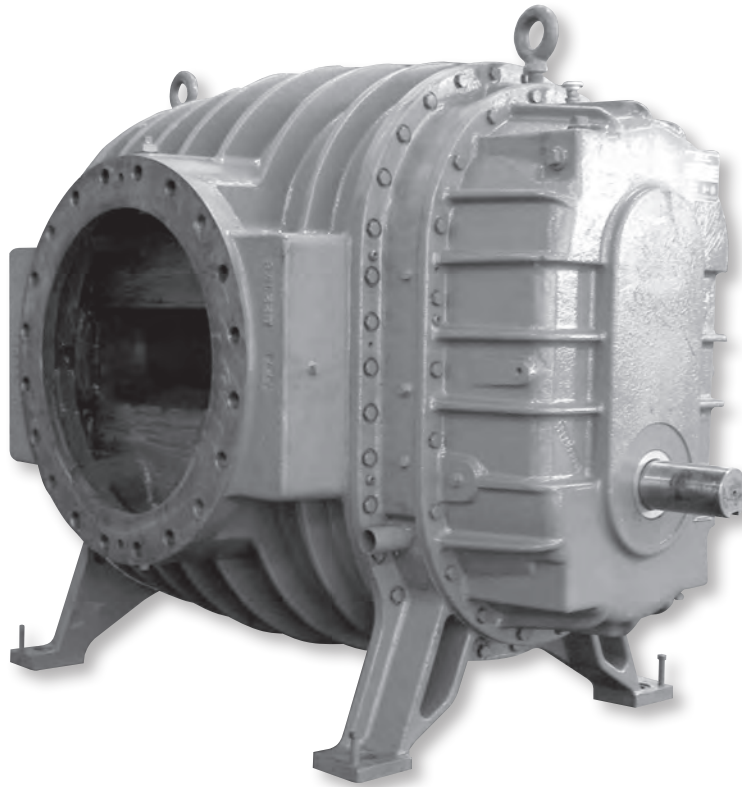

Roots® RAS and RAS-J Blower 10"-20" Splash Lubricated Installation and Operation Manual



Contents

Information Summary.....	2	Preventive Maintenance	15
Operating Characteristics.....	3	Troubleshooting Checklist	16
Operating Limitations	4	Rotary Lube Blower Vibrations.....	17
Installation	4	Maintenance/Replacements.....	17
Lubrication	12	Repair Kit Information.....	18
Operation.....	14	Parts Lists	19
Safety Precautions	14	Assembly Drawings.....	20, 21, 22, 23

Do these things to get the most from your Roots Blower

- o Check shipment for damage. If found, file claim with carrier and notify Roots.
- o Unpack shipment carefully, and check contents against Packing List. Notify Roots if a shortage appears.
- o Store in a clean, dry location until ready for installation. Lift by methods discussed under INSTALLATION to avoid straining or distorting the equipment. Keep covers on all openings. Protect against weather and corrosion if outdoor storage is necessary.
- o Read OPERATING LIMITATIONS and INSTALLATION sections in this manual and plan the complete installation.
- o Provide for adequate safeguards against accidents to persons working on or near the equipment during both installation and operation. See SAFETY PRECAUTIONS.
- o Install all equipment correctly. Foundation design must be adequate and piping carefully done. Use recommended accessories for operating protection.
- o **Make sure both driving and driven equipment is correctly lubricated before start-up. See LUBRICATION.**
- o In event of trouble during installation or operation, do not attempt repairs of Roots furnished equipment. Notify Roots, giving all nameplate information plus an outline of operating conditions and a description of the trouble.
- o Unauthorized attempts at equipment repair may void Manufacturer's warranty. It is recommended that such work be limited to the operations described in this manual, using Factory Parts. Good inspection and maintenance practices should reduce the need for repairs.

NOTE: Information in this manual is correct as of the date of publication. Roots reserves the right to make design or material changes without notice, and without obligation to make similar changes on equipment of prior manufacture.

Roots products are sold subject to Roots's general terms of sale and warranty policy; contact your nearest Roots office for more information.

Operating Characteristics

The Roots air blowers described in this manual represent both the basic type of Roots Anti-friction System (RAS) rotary lobe arrangement and the proprietary Roots RAS WHISPAIR design, with gear diameters ranging from 10 to 20 inches. All units are equipped with an effective splash oil lubrication system.

The Roots RAS Blower

The Roots RAS rotary lobe blower is a positive displacement unit; its pumping capacity is determined by size, operating speed, and inlet conditions. It has two double-lobe impellers mounted on parallel shafts and rotating in opposite directions within a cylinder closed at the ends by headplates. As the impellers rotate, air is drawn into one side of the cylinder and forced out the opposite side against the existing pressure. The differential pressure developed depends on the resistance of the connected systems.

Effective sealing of the blower inlet area from the discharge area is accomplished using very small operating clearances. This feature significantly reduces rubbing contact between rotating and stationary parts, removing the need for internal lubrication. Clearances between the impellers during rotation are maintained by a pair of accurately machined timing gears mounted on the two shafts that extend outside the air chamber.

Operation of the RAS rotary lobe blower is illustrated in Figure 1, where air flow is from right to left from inlet to discharge, with the lower impeller rotating clockwise. In Position 1, it delivers a known volume (A) to the discharge, while the space (B) between the upper impeller and cylinder wall is being filled. Counterclockwise rotation of this impeller then traps an equal volume (B) in Position 2, and further rotation delivers it to the discharge in Position 3. At the same time, another similar volume is forming under the lower impeller, and will be discharged when rotation reaches Position 1 again.

One complete revolution of the driving shaft alternately traps four equal and known volumes of air (two by each impeller) and pushes them through to the discharge. The pumping capacity of a lobe blower operating at a constant speed therefore remains relatively independent of reasonable inlet or discharge pressure variations. To change the capacity it is necessary to change the speed of rotation or vent some of the air.

The Roots RAS WHISPAIR

Operation of the proprietary Roots RAS WHISPAIR blower is represented in Figure 2. Just as in the standard Roots RAS blower, the air flow is from right to left, with the lower shaft rotating clockwise. This design differs from the basic RAS rotary blower in that it provides a chamber on the discharge side of the cylinder.

From this chamber, two or more slots open back into the two alternately closed pocket areas of the cylinder (shown as A and B). These slots, at certain impeller positions, allow discharge pressure to bleed into the normally low pressure pockets. They also provide a jet action on the impellers in the direction of rotation. Gradual pressure buildup in the pockets, to a level almost equal to the discharge pressure, reduces the backflow rate at the instant of pocket discharge, effectively minimizing pulsing and shock noise.

As shown in Position 1 in Figure 2, the known volume (A) is delivered to the discharge chamber while the space (B) is filled with an equal volume at inlet pressure. In Position 2 the space has been sealed from an inlet, but some discharge pressure is entering the space (B) through the slot passage, as indicated by the small arrows. The force of the jet assists the rotation of the impeller, while also building pressure in the sealed space (B). Rotation continues to Position 3, where the volume (B) is delivered to the discharge chamber in the same manner as the volume (A) in Position 1. Because of the almost complete pressure equalization through the slot, shock is minimized.

Notes and Warnings

With either blower design, no attempt should ever be made to control capacity by means of a throttle valve in the intake or discharge piping. This increases the power load on the driver and may seriously damage the blower. Similarly, if a possibility exists that flow to the blower inlet may be cut off during normal operations, then an adequate vacuum relief valve should be installed in the inlet line near the blower. A pressure relief valve in the discharge line near the blower is also strongly recommended for protection against cut-off or blocking in this line.

When a belt drive is employed, blower speed can usually be adjusted to obtain the required capacity by changing the diameter of one or both sheaves. In a direct-coupled arrangement, a variable speed motor or transmission is required, or air may be vented through a manually controlled unloading valve and silencer. If discharge air is returned to the blower inlet, it must go through a cooling by-pass arrangement.

Before making any change in blower capacity or operating conditions, contact the nearest Roots office for specific information applying to your particular blower. In all cases, operating conditions must be maintained within the approved range or pressures, temperatures and speeds as stated under LIMITATIONS. Also, serious damage to the rotating parts of the blower will result if it is used to handle air that contains liquids or solids.



Figure 1 - Flow Through a Basic Type RAS Blower

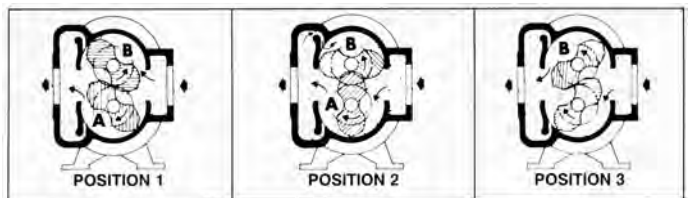

Figure 2 - Flow Through a RAS WHISPAIR Blower

Operating Limitations

A Roots blower must be operated within certain approved limiting conditions to enable continued satisfactory performance. The Roots warranty is contingent on such operation.

RAS/RGS and RAS/RGS WHISPAIR blowers are available with two types of internal blower clearances, normal and open. Maximum limits for pressure, temperature, vacuum, and speed are specified in Table 1 for both types of clearances. Verify with the factory that your blower is supplied with open clearances before operating it within the specified conditions. Do not exceed any single limit or combination of limits listed in Table 1.

Be sure to arrange connections or taps for thermometers and pressure or vacuum gauges at or near the inlet and discharge connections of the blower. These, along with a tachometer, will enable periodic checks of operating conditions.

Note: Some special purpose blowers may be assembled with non-standard clearances. These units may be operated at pressure and or temperature rises higher than those listed in applicable Table 1. However, you must request specific approval from the nearest Roots office before doing so, otherwise the warranty will be voided. Normally, when a blower is operated at the design conditions stamped on its nameplate, the specified limits apply.

Pressure- The pressure rise, between blower inlet and discharge, must not exceed the figure listed for the specific unit frame size concerned. Also, in any system where the unit inlet is at a positive pressure above atmosphere, a discharge pressure of 25 PSI (172 kPa) should not be exceeded, regardless of blower size.

Installation

Supervision of the installation by a Roots service engineer is not usually required for these units. Technicians with general experience in installing heavy machinery should be able to produce satisfactory results. However, a Roots service engineer may be engaged for assistance or for final checking of an installation.

Note: The information contained in this manual is intended to supplement more detailed discussions of foundations and piping found in API recommended practice 686 and the Compressed Air and Gas Handbook, published by the Compressed Air and Gas Institute, New York City, and the American Petroleum Institute, Washington, D.C.

Location

Because the unit is completely enclosed, the location of the installation is typically not critical. While a clean, dry, and protected indoor location is preferred, an outdoor location will generally provide satisfactory service. Important requirements are that the correct grade of lubricating oil be provided for the expected operating temperatures, and that the unit is located so that routine checking and servicing can be conveniently performed.

On vacuum service, with the discharge to atmospheric pressure, the inlet suction or vacuum must not be greater than the values listed for the specific frame size.

Temperature - Blower frame sizes are approved only for installations where the following temperature limitations can be maintained in service:

- Measured temperature rise must not exceed listed values when the inlet is at ambient temperatures. Ambient is considered as the general temperature of the space around the blower. This is not outdoor temperature, unless the blower is installed outdoors.
- If inlet temperature is higher than ambient, the listed allowable temperature rise values must be reduced by two-thirds of the difference between the actual measured inlet temperature and the ambient temperature.

Speed- Blowers may be operated at speeds up to the maximums listed for the various frame sizes. They may be directly coupled to suitable constant speed drivers if pressure/temperature conditions are also within limits.

At low speeds, excessive temperature rise may be a limiting factor.

Special Note: The listed maximum allowable temperature rise (increase in air temperature between inlet and discharge) for any particular blower may occur well before the maximum speed or maximum pressure rating is reached. This may occur at high altitude, low vacuum or very low speed. The unit's operating limit is always determined by the maximum rating reached first – pressure, temperature, or speed.

Protection

As indicated by markings on the flange covers, the internal machined surfaces of Roots blowers are treated with a vaporizing inhibitor after factory assembly to protect against normal atmospheric corrosion. Protection against chemical or saltwater atmosphere is not provided.

The maximum period of protection is one year under average conditions, if flange covers and closing seals are not removed. Leave covers and tape seals over all openings as long as possible during installation to avoid loss of protection.

If there will be an extended period between installation and startup, take the following steps to ensure corrosion protection:

- 1 Coat the insides of the cylinder, gearbox, and drive end bearing covers with a vapor phase rust-inhibiting liquid such as Nox-Rust VCI-10 or equivalent. Repeat once a year or as conditions require. VCI-10 is oil soluble and does not have to be removed before lubricating. If desired, Nox-Rust VCI-10 may be removed from within the cylinder shortly before startup by spraying a fine mist of petroleum solvent through the blower while it is running at a slow speed with open inlet and discharge, or it can remain in the blower if it is not harmful to the operation of the connected system. Nox-Rust VCI-10 may be obtained from Daubert Chemical Co., 2000 Spring Rd., Oak Brook, IL, 60521.

Table 1A - Maximum Allowable Operating Conditions (22 PSL)

Frame Size	Speed RPM	Normal Clearances - RP68						Open Clearances - RP71					
		Pressure Rise		Inlet Vacuum		Temperature Rise		Pressure Rise		Inlet Vacuum		Temperature Rise	
		psi	kPa	Inches Hg.	kPa	°F	°C	PSI	kPa	Inches Hg.	kPa	°F	°C
1006	1900	36.6	252	16	54	205	96	36.6	252	16	54	300	149
1009	1900	24.4	168	16	54	205	96	24.4	168	16	54	280	138
1012	1900	18.3	126	16	54	205	96	18.3	126	16	54	280	138
1016	1900	13.3	92	16	54	148	64	13.3	92	16	54	240	116
1018	1900	11.7	81	16	54	148	64	11.7	81	16	54	240	116
1021	1900	10.4	72	16	54	148	64	10.4	72	16	54	240	116
1024	1900	9.2	63	16	54	148	64	9.2	63	16	54	240	116
1030	1900	7.3	50	15	51	148	64	7.3	50	15	51	240	116
1212	1600	22.0	152	16	54	223	106	22.0	152	16	54	280	138
1216	1600	16.5	114	16	54	223	106	16.5	114	16	54	280	138
1220	1600	13.2	91	16	54	148	64	13.2	91	16	54	235	113
1222	1600	11.7	81	16	54	148	64	11.7	81	16	54	235	113
1225	1600	10.5	72	16	54	148	64	10.5	72	16	54	235	113
1228	1600	9.2	63	16	54	148	64	9.2	63	16	54	235	113
1236	1600	7.3	50	15	51	148	64	7.3	50	15	51	235	113
1412	1365	24.6	170	16	54	230	110	24.6	170	16	54	280	138
1414	1365	21.2	146	16	54	230	110	21.2	146	16	54	280	138
1418	1365	16.6	114	16	54	230	110	16.6	114	16	54	280	138
1422	1365	13.7	94	16	54	140	60	13.7	94	16	54	230	110
1425	1365	12.2	84	16	54	140	60	12.2	84	16	54	230	110
1428	1365	11.0	76	16	54	140	60	11.0	76	16	54	230	110
1431	1365	9.8	68	16	54	140	60	9.8	68	16	54	230	110
1435	1365	8.8	61	16	54	140	60	8.8	61	16	54	230	110
1442	1365	7.3	50	15	51	140	60	7.3	50	15	51	230	110
1616	1200	22.0	152	16	54	230	110	22.0	152	16	54	280	138
1620	1200	17.6	121	16	54	230	110	17.6	121	16	54	280	138
1625	1200	14.0	97	16	54	230	110	14.0	97	16	54	280	138
1627	1200	13.0	90	16	54	140	60	13.0	90	16	54	230	110
1630	1200	11.7	81	16	54	140	60	11.7	81	16	54	230	110
1633	1200	10.6	73	16	54	140	60	10.6	73	16	54	230	110
1636	1200	9.8	68	16	54	140	60	9.8	68	16	54	230	110
1639	1200	9.0	62	16	54	140	60	9.0	62	16	54	230	110
1643	1200	8.2	57	16	54	140	60	8.2	57	16	54	230	110
1645	1200	7.8	54	16	54	140	60	7.8	54	16	54	230	110
1648	1200	7.3	50	15	51	140	60	7.3	50	15	51	230	110
1821	1060	18.8	130	16	54	230	110	18.8	130	16	54	280	138
1824	1060	16.5	114	16	54	230	110	16.5	114	16	54	280	138
1827	1060	14.6	101	16	54	230	110	14.6	101	16	54	280	138
1830	1060	13.2	91	16	54	140	60	13.2	91	16	54	230	110
1833	1060	11.7	81	16	54	140	60	11.7	81	16	54	230	110
1838	1060	10.4	72	16	54	140	60	10.4	72	16	54	230	110
1841	1060	9.6	66	16	54	140	60	9.6	66	16	54	230	110
1845	1060	8.8	61	16	54	140	60	8.8	61	16	54	230	110
1849	1060	8.0	55	16	54	140	60	8.0	55	16	54	230	110
1854	1060	7.3	50	15	51	140	60	7.3	50	15	51	230	110
2022	1000	19.6	135	16	54	225	107	19.6	135	16	54	280	138
2026	1000	14.7	101	16	54	135	57	14.7	101	16	54	225	107
2030	1000	14.7	101	16	54	135	57	14.7	101	16	54	225	107
2033	1000	13	90	16	54	135	57	13	90	16	54	225	107
2037	1000	11.7	81	16	54	135	57	11.7	81	16	54	225	107
2040	1000	11	76	16	54	135	57	11	76	16	54	225	107
2044	1000	10	69	16	54	135	57	10	69	16	54	225	107
2047	1000	9.4	65	16	54	135	57	9.4	65	16	54	225	107
2050	1000	8.8	61	16	54	135	57	8.8	61	16	54	225	107
2055	1000	7.9	54	16	54	135	57	7.9	54	16	54	225	107
2057	1000	7.7	53	16	54	135	57	7.7	53	16	54	225	107
2060	1000	7.3	50	15	51	135	57	7.3	50	15	51	225	107

Table 1B - Maximum Allowable Operating Conditions (40 PSL)

Frame Size	Speed RPM	Normal Clearances - RP68						Open Clearances - RP71					
		Pressure Rise		Inlet Vacuum		Temperature Rise		Pressure Rise		Inlet Vacuum		Temperature Rise	
		psi	kPa	Inches Hg.	kPa	°F	°C	PSI	kPa	Inches Hg.	kPa	°F	°C
2022	1000	36.3	250	16	54	225	125	36.3	250	16	54	280	155
2026	1000	30.7	211	16	54	225	125	30.7	211	16	54	280	155
2028.5	1000	28.0	193	16	54	225	125	28.0	193	16	54	280	155
2030	1000	26.7	184	16	54	225	125	26.7	184	16	54	280	155
2033	1000	24.2	167	16	54	135	75	24.2	167	16	54	225	125
2037	1000	21.3	147	16	54	135	75	21.3	147	16	54	225	125
2040	1000	20.0	138	16	54	135	75	20.0	138	16	54	225	125
2044	1000	18.1	125	16	54	135	75	18.1	125	16	54	225	125
2047	1000	17.0	117	16	54	135	75	17.0	117	16	54	225	125
2050	1000	16.0	110	16	54	135	75	16.0	110	16	54	225	125
2053	1000	15.0	104	16	54	135	75	15.0	104	16	54	225	125
2055	1000	14.5	100	16	54	135	75	14.5	100	16	54	225	125
2057	1000	14.0	97	16	54	135	75	14.0	97	16	54	225	125
2060	1000	13.3	92	16	54	135	75	13.3	92	16	54	225	125
2062	1000	12.9	89	16	54	135	75	12.9	89	16	54	225	125
2064	1000	12.5	86	16	54	135	75	12.5	86	16	54	225	125
2070	1000	11.4	79	16	54	135	75	11.4	79	16	54	225	125
2072	1000	11.1	77	16	54	135	75	11.1	77	16	54	225	125
2077	1000	10.4	72	16	54	135	75	10.4	72	16	54	225	125
2080	1000	10.0	69	16	54	135	75	10.0	69	16	54	225	125

Note: If material of construction for impeller or casing is stainless steel, temperature rise limits are reduced by 50%. Only Open Clearance, RP-71, is used with stainless steel construction and typical limit is 120°F (67°C)

- 2 Paint the shaft extension, inlet and discharge flanges, and all other exposed surfaces with Nox-Rust X-110 or equivalent.
- 3 Seal the inlet, discharge, and vent openings. It is not recommended that the unit be set in place, piped to the system, and allowed to remain idle for extended periods. If any part is left open to the atmosphere, the Nox-Rust VCI-10 vapor will escape and lose its effectiveness.
- 4 Protect the equipment from excessive vibration during storage.
- 5 Rotate the drive shaft three or four revolutions every two weeks.
- 6 Prior to startup, remove the flange covers on both the inlet and discharge and inspect the interior to ensure the absence of rust. Check all internal clearances. Also, remove the gearbox and bearing covers and inspect the gear teeth and bearings for rust.

Before connecting the piping, remove the main flange covers and inspect the blower interior for the presence of foreign particles or dirt adhering to machined surfaces. Use petroleum solvent to carefully wash away any material found and then manually rotate the impellers to ensure that they turn freely. Use the same solvent to remove the anti-rust coating from the flange faces and any other surfaces. Note: Interior cleaning is not required if no dirt is found.

Equipment Handling/Lifting

Handling of the Root blower equipment needs to be accomplished with care, and in compliance with safe practices. The weight of a bare unit, without the base plate, driver, or accessories, ranges from about 1 ton (910 kg) for the smallest units to approximately 7 tons (6350 kg). On RAS and RAS-J units, an eyebolt is provided near each end for lifting. Units mounted on a base plate have greater weight and should always be handled using the four lifting hooks provided.

Check the eyebolts for tightness, by tapping with a hammer, before lifting the equipment by the eyebolts. Make sure to pull the bolts in a nearly vertical direction when lifting. To ease the side strain caused by a large cable angle, place a stiff spreader between the eyebolts and adjust the cable lengths so that the unit is approximately level during the lift.

Note: A harness with four lifting hooks is required to lift base-mounted units. After inserting the hooks in the lifting lugs, block the chains out on the sides to avoid placing the unit under strain. At the same time, adjust the lengths to produce a level lift.

Foundation

Because many factors, including local soil conditions, impact the foundation design, this section offers only a general discussion that is intended to be supported by information from the Compressed Air and Gas Handbook referenced earlier. To ensure satisfactory equipment operation, the concrete foundation must be rigid, have minimal defects, and should not be resonant in the frequencies of the operating speed range of the equipment.

The foundation's length and width must provide at least 6 inches (150 mm) from any edge to the nearest machine anchor bolt (based on the location indicated in the certified manufacturer's general arrangement drawing). The depth dimension should be determined by design, with a minimum practical depth considered to be twice the distance between the shaft centers (or gear diameter) of the unit, or sufficient depth to attain a concrete mass a minimum of one-and-a-half times the weight of the blower and motor.

The concrete block needs to cure for a minimum of 28 days before the blower is grouted in place. Any block distortions during curing will have little or no effect on equipment and alignment. To simplify machine leveling and provide a good grouting bond, the top of the foundation should be struck off as level as possible, but left with a rough surface.

We do not recommend spring-type vibration isolating mounting for use directly between the operating equipment and the foundation. When such mountings are required, they should be designed to carry a reinforced concrete slab on which the equipment is mounted. The slab must offer good rigidity against bending and twisting. The suspension system requires careful adjustment to produce a reasonably level condition during operation. All piping requires flexible sections and supports to reduce connection strains on the unit.

We also do not recommend the direct use of structural framing members for mounting the blower base to a building structure. If this is unavoidable, it should be restricted to smaller frame size units, and spring-type mountings should not be used. Structural members must be rigid, and will probably require reinforcement if they are part of a building. Noise transmission can be reduced by using a cork isolation pad to reduce the transfer of vibration from the blower base to the building structure. The pad should be 1 to 2 inches (25-50 mm) thick, bedding on a full steel plate attached to the structure and carrying the rigid concrete slab on which the equipment is mounted.

Anchor Bolts and Plates - Place anchor bolts within the foundation forms before the concrete is poured. (See Table 2 for the recommended bolt sizes and Figure 3 for proper bolt installation.) The bolts must be located as accurately as possible based on the dimensions provided on the certified installation drawing. To obtain a bolt location tolerance of 1/8-inch (3mm), use drilled templates firmly secured to the foundation forms.

It is important to keep the bolt sleeves centered around the bolts and free of concrete to allow the bolts to be sprung enough to correct for small variations in bolt setting and machine drilling. The sleeves are filled in the final grouting operation. Adjust the bolt positions vertically so that the top ends extend at least one-and-a-half diameters above the soleplate or taper washer, or as shown on the installation drawing.

Use the provided jack screws for easier height adjustment leveling. Place steel plates, approximately 4" x 4" x 1/2" (100 x 100 x 13 mm), on the foundation under each jack screw location. Plates and anchor bolts are not furnished as standard accessories.

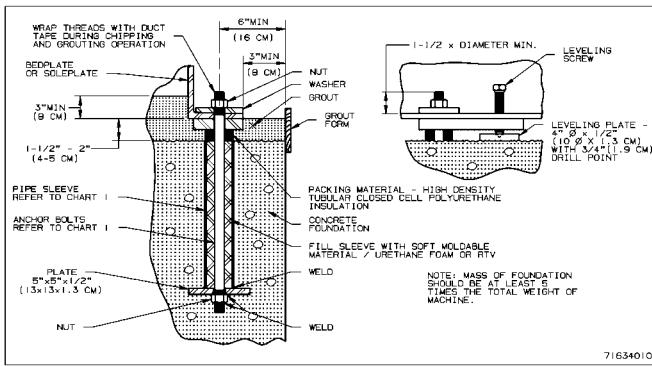

Figure 3 - Typical Anchor Bolt Detail

Table 2A – Standard Anchor Bolts in Inches

Unit Frame Size	For Soleplates				For Baseplates			
	Bolts		Sleeves		Bolts		Sleeves	
	Dia.	Lgth.	I.D.	Lgth.	Dia.	Lgth.	I.D.	Lgth.
1000	1	24	2	12	3/4	18	2-1/2	13
1200	1	24	2	12	3/4	18	2-1/2	13
1400	1-1/8	36	2-1/4	18	3/4	18	2-1/2	13
1600	1-1/8	36	2-1/4	18	1	24	3	18
1800	1-1/4	36	2-1/4	18	1	24	3	18
2000	1-1/4	36	2-1/4	18	1	24	3	18

Table 2B – Standard Anchor Bolts in (cm)

Unit Frame Size	For Soleplates				For Baseplates			
	Bolts		Sleeves		Bolts		Sleeves	
	Dia.	Lgth.	I.D.	Lgth.	Dia.	Lgth.	I.D.	Lgth.
1000	2.4	60	5.0	30	2.0	46	6.5	33
1200	2.4	60	5.0	30	2.0	46	6.5	33
1400	3.0	90	6.5	46	2.0	46	6.5	33
1600	3.0	90	6.5	46	2.4	60	8.0	46
1800	3.0	90	6.5	46	2.4	60	8.0	46
2000	3.0	90	6.5	46	2.4	60	8.0	46

Leveling

Because the unit should be as level as possible in all directions, we recommend performing this critical step using a good quality machinist's level with a ground glass bubble vial. Level the blower from the drive shaft and pipe flanges. Machined baseplates have pads running along both the length and width. On soleplates, the machined top surfaces are used for leveling. Scrape the pads or surfaces clean, and use a flat file to remove burrs on the high points.

When the blower and driver are factory mounted on a common baseplate, treat the assembly as a unit for leveling purposes. Use the jack screws to establish the grouting space under the base flanges and to level the base. Adjust the screws until the indicated variation from the level does not exceed .001 inch per foot (.08 mm per meter) in either length or width. To reduce twist, any variations should all be in the same direction. The maximum allowable twist is .001 inches per horizontal foot (.08 mm per horizontal meter) measured between any two sections of the base.

Units that are mounted on soleplates can be leveled in a similar manner. The plates should be large enough to provide extensions for leveling in both length and width on the finished upper surfaces. Solidly fasten the plates to the blower feet, which are machined flat and parallel to each other. Then install and level the blower carefully, using jack screws, shims, or wedges for adjusting. It is very important to eliminate twist. Minor adjustments can be made by

placing shims directly under the blower feet. When a satisfactory level condition is obtained, turn the anchor bolt nuts down snug, but not tight.

Aligning

When the blower unit and its driver are direct coupled, careful attention is required to align the drive shafts. Precise alignment helps ensure satisfactory coupling operation, as well as significantly reducing the chance of damage to either the driving or driven unit from vibration or thrust forces.

For package units with the driver and blower mounted on a common baseplate, the two shafts have been placed in approximate alignment at the factory. Because baseplate deflections can occur during shipping and installation, it is important to obtain a close coupling alignment during leveling to ensure that only small final adjustments will need to be made after grouting.

For soleplate applications, the separately mounted driver must be positioned, leveled, and aligned during installation.

Whether the unit is on soleplates or its own base, place shims (1/16 to 1/8 inch (2-3 mm) thick) directly under the driver feet before setting the unit in place to achieve more accurate final alignment. Establish spacing between the two shaft ends as required by the coupling. If a motor is being used that has end play in the shaft, be sure its rotor is located on magnetic center before setting this spacing. It also needs a limited end float kit.

When the blower is driven through V-belts, the driver must be mounted on an adjustable base to permit tightening or removing of the belts. In this case, the driver shaft height is of no concern, but it must be parallel to the blower shaft and level. To position the driver properly, mount both sheaves on their shafts (the shaft center distance must be known).

Install the narrow hub type of blower sheave (usually the one with a larger diameter) so that its inner hub face is not more than 1/4 inch (6 mm) away from the bearing housing end cover. The driver sheave should also be mounted as close to its bearing as possible. Position the driver so that the faces of the two sheaves are accurately in line, with the adjustable base located so that two-thirds of its total available movement is in the direction away from the blower. This positioning provides minimum belt wear and slip, and allows sufficient adjustment for installing and tightening the belts. Do not install the belts until the grouting has set and the anchor bolts are tightened.

Blowers to be driven by v-belts may be provided with an extended drive shaft and an additional outer bearing to handle the side pull of the drive. Identified by the extended housing for the outer bearing, these blowers can also be driven by direct coupling to the motor if necessary.

Note: Blowers intended specifically for direct coupling have no outer bearing, and can be seriously damaged if used for belt drive applications. Consult your Roots sales office before belting these units.

Grouting

The final leveling step – and a preliminary alignment step – involves grouting the foundation.

After proper curing, create a roughened top surface by chipping away glazed areas and removing oil or grease using a strong hot detergent or caustic solution.

Grouting compensates for surface irregularities in the foundation and machine base and also helps restrain shifting. Because anchor bolts are used for hold-down only, the grout under the soleplate or base flange must be adequately thick, it must flow into the anchor bolt sleeves and all interior cavities, and it must be a variety that offers minimal shrinkage during the setting period. Due to the open frame design, the bedplate should be filled with concrete that is level with the top of the main channels.

Special grouting materials designed to counteract shrinkage are commercially available and are often preferred to cement. Follow the manufacturer's instructions when using these materials. Care must be exercised when employing non-shrink additives with cement, as too much can be worse than none. Any gas-forming or air-entraining additives should be avoided, because they tend to reduce grout strength.

Wait at least 24 hours before tightening anchor bolts or connecting piping. When jack screws have been used for leveling, make sure the bottom of the leveling screw is treated according to the grout manufacturer's instructions

so that it can be backed off. Such points of concentrated loading are likely to wear during machine operation, resulting in loose anchor bolts. Final bolt tightening should only be enough to hold the machine firmly against the foundation and prevent vibration.

After all anchor bolts are secured, recheck the blower for twist and level. Working from the finished pad on top of the cylinder, make corrections to meet the requirements specified under LEVELING by shimming under the blower feet. Then rotate the drive shaft by hand to make sure both impellers turn freely at all positions.

When the blower is directly coupled to its driver, final alignment of the two shafts should be accomplished by very carefully adjusting the shims under the driver feet. While a flexible coupling can accept some degree of misalignment, it should not be forced to compensate for careless workmanship. The flexing or sliding member in a coupling transmits undesirable forces between the two shafts in proportion to the degree of misalignment, thus promoting vibration and unnecessary wear problems.

The two basic types of misalignment – offset and angular – often occur together. Use the following limits to achieve satisfactory coupling operation: maximum deviation in offset alignment not greater than .005 inches (.13 mm) total indicator reading on the coupling hubs, and maximum deviation from parallel of the inside coupling faces not greater than .001 inches (.03 mm) when checked at six points. When the driver is a steam turbine, the final alignment should be made with the turbine at operating temperature in order to allow for shaft movement resulting from expansion.

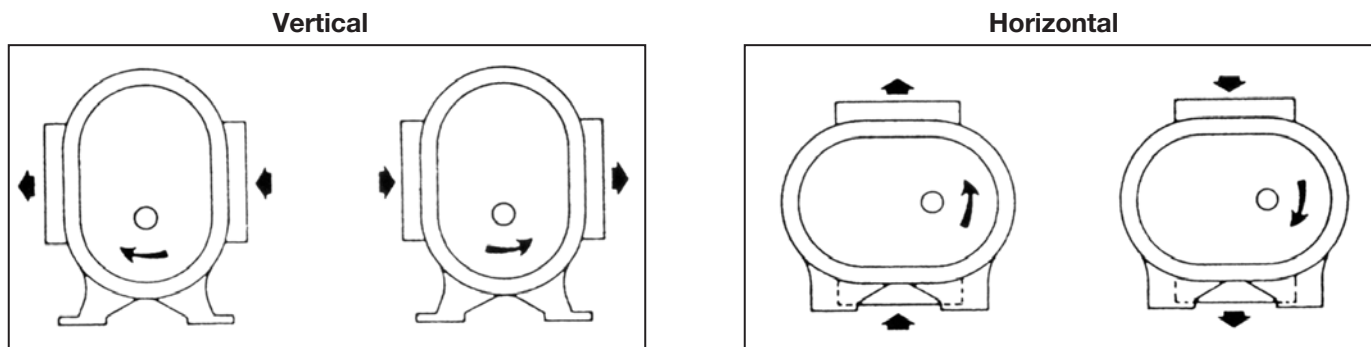

Figure 4 – Rotation and Discharge, Vertical and Horizontal RAS and RAS WHISPAIR Blowers

Piping

Before connecting the piping, thoroughly clean it. The piping should be sized so that air velocity in the line does not exceed 100 feet per second (30 m per second). When a blower is operated at or near its maximum volume rating, the piping should be no smaller than the blower connections. Use long radius elbows whenever possible to ensure smooth flow. Design the piping layout so that no strain is placed on the blower, either from weight or expansion forces. Provide adequate supports, anchors, and expansion joints or loops.

We recommend installing a spool-type rubber expansion joint near the blower inlet connection. In addition, a similar unit with control elements added to minimize piping vibrations may be required near the discharge. Depending on the blower speed, operating pressure, length and type of

piping, and surrounding area sound level requirements, the use of snubbers or silencers in the inlet or discharge piping may be necessary. For specific silencer recommendations, contact your nearest Roots sales office.

Typically, inlet piping should be free of valves or restrictions, but when a shutoff valve cannot be avoided, make sure a full-size vacuum relief valve is installed near the blower inlet connection (see Figure 5). This will protect against an overload caused by accidental valve closing. Further protection can be provided by installing a dependable pressure-sensitive device with an alarm or shutdown action.

During initial operation, install a temporary corrosion-resistant screen at the compressor inlet connection. The screen should be made of 16 mesh (.020 inch diameter) wire

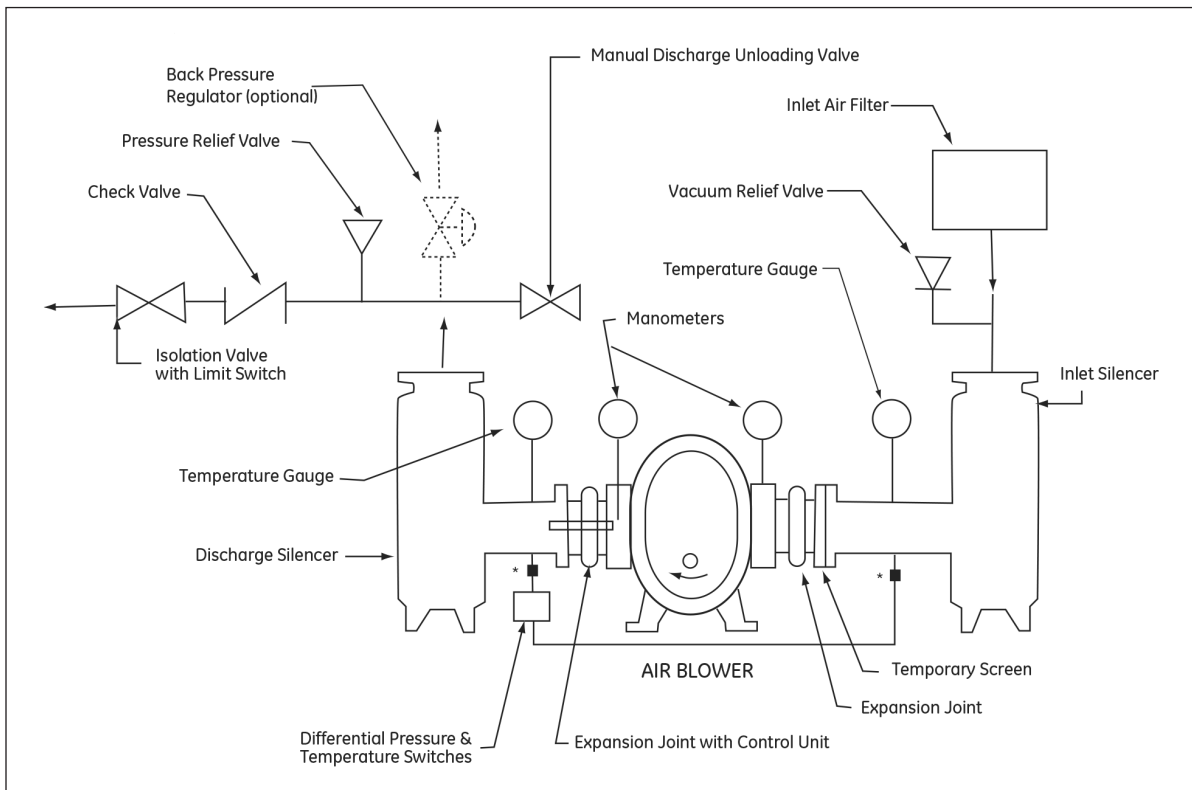

Figure 5 – Installation with Suggested Locations for Available Accessories

backed with 2 mesh wire cloth. The backing cloth-wire diameter should be a minimum of:

- 0.063 inch diameter for 12-inch pipe
- 0.080 inch diameter for 16-inch pipe
- 0.105 inch diameter for 20-inch pipe
- 0.120 inch diameter for 24-inch pipe

For 30" and 36" pipe use 1 mesh backing cloth with a minimum of 0.180-inch wire diameter for 36-inch pipe.

The table below provides the approximate screen pressure drop. To determine when the piping needs to be cleaned, connect a manometer to measure the pressure drop across the screen. Do not allow the pressure drop to exceed 55 inches H₂O. Clean and replace the screen until debris no

longer appears, and then remove the screen. Typically, screens are installed for the first one to two days of operation. If the screen is left in place, the wire will eventually deteriorate and wire fragments may enter the blower and cause serious damage.

Discharge piping requires a pressure relief valve, and should also include a suitable pressure gauge and a manually operated unloading valve. The unloading valve permits starting under no-load conditions. The optional back pressure regulator shown in Figure 5 is required if volume demands vary while the blower operates at a constant speed. It may be vented if only air is being handled. Depending on permissible sound levels in the general surroundings, a vent silencer may be required.

In some installations, particularly when two or more blowers discharge into a common header, we recommend that a direct acting or free swinging check valve be provided in each discharge line. These valves protect against damage resulting from reverse rotation caused by back flow through an idle blower.

Carefully line up the mating flanges when making pipe connections to the blower. They must contact squarely and accurately, without imposing strain on the blower casing. Any attempt to draw flanges together by force will likely distort the blower and cause internal contacts. The blower should not carry more than the weight of one pipe fitting at each connection. After bolting up the flanges, rotate the drive shaft by hand to check for rubbing contacts caused by strains or dirt.

Approximate Screen Pressure Drop, Inches H₂O (16 Mesh, .020" Wire Dia.)

Flow (ACFM)	Pipe Diameter (Inches)						
	12"	16"	20"	24"	30"	36"	42"
2,500	3.0	1.1	0.3	0.3	-	-	-
5,000	12.7	3.9	1.7	0.8	-	-	-
10,000	-	15.5	6.4	3.0	1.3	-	-
15,000	-	-	14.4	7.2	2.8	1.4	-
20,000	-	-	-	12.7	5.1	2.4	1.4
30,000	-	-	-	-	11.4	5.5	3.0
45,000	-	-	-	-	-	12.3	7.0
60,000	-	-	-	-	-	-	12.5

V-Belt Drives

Recommendations:

- **V-Belt Drive ONLY suitable for Opposite Gear End (OGE) Drive units. V-Belt Drive NOT suitable for Gear End (GE) Drive units.**
- Attempting to belt drive with a motor in excess of 200 HP will make it difficult to size a drive without exceeding the maximum shaft loads. To belt drive over 200 HP generally requires a jackshaft with pillow block bearings connected to the blower by a coupling.
- Use a minimum of 1.4 service factor on the drive horsepower.
- Vertical units must be driven with the motor on the inlet side. Horizontal units must be driven from the drive shaft side.
- Use molded notch belts, power band type where possible.
- The contact arc of the smaller sheave is not to be less than 170°.

Gear Diameter	Dimension "A" (Inches)		Maximum Allowable Shaft Load (Lb./In.)
	With Inboard Bearing	W/O Inboard Bearing	
10"	2.32	4	11,000
12"	2.55	4.09	15,000
14"	2.58	4.55	21,000
16"	N/A	4.97	40,500
18"	N/A	5.68	63,000
20"	N/A	6.05	70,000

$$\text{Belt Pull (Lbs.)} = (275,000 \times \text{Motor HP}) / (\text{Blower RPM} \times \text{Sheave Diameter})$$

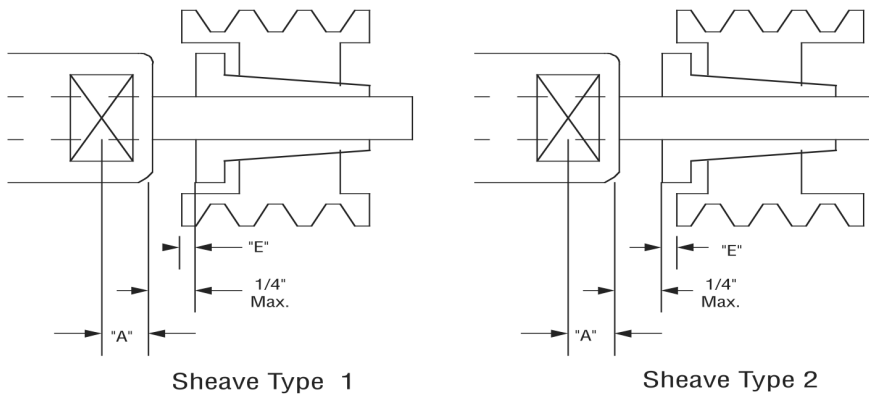

$$\text{Shaft Load (Lb.-In.)} = \text{Belt Pull} \times (\text{A} + 1/4" \text{ (+ or - E see below *)} + \text{Sheave width} / 2)$$

* Subtract "E" if sheave type 1 is used, Add "E" if sheave type 2 is used.

Lubrication

Separate Opposite Gear End Reservoirs

Roots blowers use a simple and reliable splash lubrication system. All friction parts -- gears, bearings, and shaft seals -- are lubricated by dipping them directly into oil reservoirs or by splash oil from other rotating parts. All reservoirs require the same grade of oil as specified in Table 3 for various ambient temperature ranges at the installation site.

At the opposite gear end of the blower, the upper (or driven) shaft bearing is lubricated from its own oil reservoir, formed by the bearing carrier (6) and the deep blind end cover (5A). At a normal oil level, bearing rollers dip into the oil as they roll through the bottom of their raceway. The oil picked up is carried over the top by bearing rotation, and some of it transfers to the shaft behind the bearing to lubricate the dynamic lip-type inboard seal (27). A slight amount of oil may work through this seal, but it will be thrown off by the shaft slinger, and it will be further prevented from reaching the air chamber by a labyrinth-type seal where the shaft passes through the headpiece. The chamber between the two sealing points is vented to atmosphere and serves not only to drain any seal leakage but also to keep the lubrication system at atmospheric pressure.

Table 3 - Recommended Lubrication Oils

Ambient Temperature	Viscosity Range, SSu at 100% °F (83°C)
Above 90°F (32°C)	1000-1200
32° to 90°F (0°-32°C)	700-1000
0° to 32°F (-18°-0°C)	500-700
Below 0°F (-18°C)	300-500

At the lower (driving) shaft, the arrangement is the same as described above when a short shaft for direct coupling is provided. An outboard shaft seal (23) is provided in the end cover (5). On V-belt driven blowers, the drive shaft and bearing carrier (63) are extended and provided with an additional inboard bearing (60). This creates a larger reservoir requiring about three times as much oil to fill. Lubrication is the same as for the shorter shaft, except that two protruding screws (96) are provided to ensure adequate splash oil for the bearing (60).

At the gear end of the blower, the bearings, seals, and timing gears are enclosed by a gearbox containing a double (primary and secondary) oil sump arrangement. In a vertical-style blower, the secondary sump is formed of sheet steel and contoured around the bottom half of the lower gear. It is fed with oil at a controlled rate from the surrounding primary sump in the gearbox itself, through a metering orifice in the secondary wall. The lower gear teeth pick up oil and carry it to the meshing point with the upper gear, where it is splashed onto oil control shields with leaders that direct the oil to the two bearings. A dam at each bearing maintains the desired oil level there, with excess overflowing into the gearbox primary sump. Inboard sealing of the shafts is the same as at the drive end. In a horizontal style blower, the gear end lubrication arrangement is identical, except that a secondary sump is formed around each gear and the total oil capacity is more than doubled.

Note: A high-quality grade of industrial-type non-detergent, anti-foaming oil should be used when the average of blower inlet and discharge temperature is 125°F (52°C) or lower. Oil should be changed after the first 100 hours of operation. After the initial oil change, the normal oil change periods under these conditions are every 2,000 operating hours. At higher temperatures these oils

may turn black and leave carbon deposits. For average temperatures above 125°F (52°C), we recommend that oil with an efficient

oxidation inhibitor be used, and that the change interval should be reduced. Shell TELLUS is a suitable oil type with the required characteristics. Equivalent oils from other suppliers are assumed to be comparable in performance. Suggested oil change periods for the higher operating temperatures are as follows:

Average Temp. °F (C°)	Operating Hrs.
Below 150 (65)	1000
151-160 (66-71)	500

Above an average temperature of 180°F, a synthetic oil like Roots* Synfilm ST Synthetic Oil should be used.

On the gearbox and the two opposite gear end bearings sumps, oil levels are indicated in sight windows. All three sight windows are completely unobstructed circular discs, allowing the oil level to always be in view.

Approximate capacities in gallons or fluid ounces for the three sump locations are given in Table 4 as a guide. Actual filling requirements may vary slightly from the listed figures. Select a good industrial grade of oil per Table 3 for your existing ambient temperature conditions.

To establish the correct oil levels, fill the oil sump when the blower is not operating. At the gearbox, remove the top vent plug (37) and pour in slightly less oil than indicated in Table 4 for the appropriate blower size, or add the oil until it rises to the center of the sight glass. Wait several minutes for the levels to equalize between the primary and secondary sumps, then add more oil if needed, or drain excess at the plug (67).

The opposite gear end sumps use constant level oilers. To fill the sumps, remove the top glass reservoir. Fill it with oil, place it on its holder, and let the bottle empty to fill the sump. To obtain proper oil level in the sump that is toward the center of the sight glass (90), pull out the level adjuster (A) shown in Figure 6 and raise or lower the cross-arm (B) as needed. Secure the cross arm with the lock (C), drop the assembly back into the lower reservoir, and replace the bottle. Note: Raising the cross arm (B) raises the oil level, and lowering it lowers the oil level.

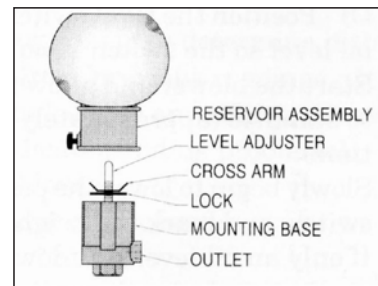

Figure 6

During operation the sump levels can be expected to fluctuate. At the gearbox sight window the level will rise as a result of oil being thrown out of the secondary sump (oil pan) into the primary sump. A satisfactory oil level is assured as long as it is visible in the window. A blower should not be operated when the oil is either above or below the circle on the sight window.

Table 4 - Oil Sump Capacities

Blower Frame Size	Gearbox - gallons (liters)		Opposite Gear End Bearings - fluid oz. (liters)		
	Vertical	Horizontal	Driven Shaft	Drive Shaft Coupled	Drive Shaft Belted
1000	3/4 (2.8)	2 (7.6)	4 (.12)	4 (.12)	12 (.36)
1200	1-1/2 (5.7)	3-1/2 (13)	5 (.15)	5 (.15)	16 (.47)
1400	1-3/4 (6.6)	4 (15)	8 (.24)	8 (.24)	28 (.83)
1600	2-1/2 (9.5)	5-3/4 (22)	9 (.27)	9 (.27)	x
1800	3 (11)	7-1/2 (28)	16 (.47)	16 (.47)	x
2000	4 (15)	9-3/4 (37)	19 (.56)	19 (.56)	x

Oil levels at the opposite gear end will fall slightly during operation because of the apparent “loss” carried in the bearings and on the shafts. If the level is visible in the sight glass, a satisfactory amount of oil is present.

During the first week of blower operation, check the oil level daily and watch for leaks. Replenish oil as necessary. Thereafter, an occasional check should be sufficient. Drain plugs (67 and 88) are provided at the bottom of the gearbox and bearing sumps.

Common Opposite Gear End Reservoirs

Some blowers are equipped with a common reservoir on the opposite gear end. The small reservoirs are replaced with a large cover similar to that covering the gear end. The oil is transmitted to the bearings by use of a slinger plate that dips into the oil. The oil is then captured and directed to the bearings by oil control shields. Refer to the sectional drawings at the back of this manual for help in better understanding this system.

The lubrication of the gear end of the blower is accurately described in the previous section.

Refer to Table 5 to determine the approximate opposite gear end oil sump capacity.

Some blowers using the common O.G.E. reservoir are supplied with oil level switches. The recommended procedure for setting these switches is as follows:

- 1 Prior to starting the blower:
 - Add oil to the reservoirs until the level is in the center of the bullseye sightglasses.
 - Disconnect the level switch from the blower shut down system.
 - Position the level switch slightly above the oil level so the switch is not as yet reset.
- 2 Start the blower and allow the oil temperature to stabilize (approximately 1/2 hour running time).
- 3 Slowly begin to lower the position of the oil level switch and mark the height at which it resets.
- 4 If only an oil level shutdown is to be used, continue to lower the switch until it is 3/4 inch below the position where the switch is reset, and lock it in place.
- 5 If an oil level alarm is to be used jointly with a shutdown, lower the switch 1/2 inch below the point where the alarm switch is reset, and lock it in place.

Lip seal oil leakage - A small amount of oil seal leakage always occurs at the drive shaft seal and the headplate seals because the unit requires this film under the lip for proper operation. This oil should be wiped off of the blower and base plate surfaces periodically, to prevent buildup.

Table 5 - Common O.G.E. Sump Capacities

Blower Frame Size	Gearbox Gal. (liters)		O.G.E. Gal. (liters)	
	Vertical	Horizontal	Vertical	Horizontal
1000	3/4 (2.8)	2 (7.6)	3/4 (2.8)	2 (7.6)
1200	1-1/2 (5.7)	3-1/2 (13)	1-1/2 (5.7)	3-1/2 (13)
1400	1-3/4 (6.6)	4 (15)	1-3/4 (6.6)	4 (15)
1600	2-1/2 (9.5)	5-3/4 (22)	2-1/2 (9.5)	5-3/4 (22)
1800	3 (11)	7-1/2 (28)	3 (11)	7-1/2 (28)
2000	4 (15)	9-3/4 (37)	4 (15)	9-3/4 (37)

Operation

Before operating a blower for the first time, thoroughly recheck the unit installation using the following procedure checklist as a guide. In addition, make sure to consider any special conditions of your installation.

- 1 Ensure that no bolts, tools, rags, or debris have been left in the blower air chamber or piping.
- 2 If you are using an outdoor intake without a filter, ensure that the opening is clean and protected by a strong screen. Use of a temporary protective screen at the blower inlet as described under INSTALLATION is strongly recommended during early operation.
- 3 If the installation was not performed recently, recheck the blower leveling, drive alignment, belt tension, and tightness of all mounting bolts.
- 4 Hand turn the drive shaft to make sure that the impellers rotate without bumping or rubbing at any point.
- 5 Check that the blower lubrication system oil levels are at the center of the sight glasses.
- 6 Check that the driver (and gear unit if supplied) is properly lubricated. Make sure that power is available and that all electrical overload and safety controls are installed and workable.
- 7 Open the manual unloading valve in the discharge air line. Make sure that any blocking valve in the inlet piping is open.
- 8 Bump the blower a few revolutions with the driver to ensure that the direction of rotation agrees with the arrow near the blower shaft and to make sure that both units coast freely to a stop.

After completing the check list items above, the blower is ready for trial operation under “no-load” conditions. The following procedure is suggested for this initial operation test period.

- 9 Start the blower, let it accelerate to full speed, and then shut it off. Listen for any knocking sounds, both with the power on and also as it slows down.
- 10 If no problems have been noted, after the blower comes to a complete stop, restart the unit and let it operate for 5 to 10 minutes under no-load conditions. Feel all of the cylinder surfaces for any hot spots indicating impeller rubs. Continue to listen for noises and watch for changes in vibration.
- 11 If all conditions are acceptable, continue operating the unit, while gradually closing the discharge unloading valve to replicate normal operating conditions as closely as possible. We recommend using high-quality pressure and vacuum gauges and thermometers in both inlet and discharge locations to measure pressure and temperature rises across the blower. Observe the pressure increase as the unloading valve is closed, and do not allow it to exceed the rating of the specific blower as listed under LIMITATIONS.

- 12 If all conditions remain satisfactory, continue the run for about one hour. Observe the pressure and temperature rise periodically to make sure neither exceeds the specified limits. Continue to check for noises and hot spots, and observe oil level behavior at the three sumps. If trouble appears, refer to the TROUBLESHOOTING CHECKLIST for suggested remedies.

The blower should now be ready for continuous duty under full load. During the first several days, periodically verify that all conditions remain reasonably steady and within limits. These checks may be especially important if the unit is part of a process system where conditions may vary. At the first opportunity, stop the blower and clean or remove the temporary inlet protective screen. If no appreciable amount of debris has collected, the screen may be removed. See comments under INSTALLATION. Also, verify leveling, coupling alignment or belt tension, and anchor bolt tightness.

If operating experience indicates that the blower’s capacity is a little too high for the actual requirements, a small excess may be blown off continuously through the manual unloading or vent valve. Never rely on the pressure relief valve as an automatic vent because it may cause the discharge pressure to become excessive, and can also result in valve failure. If the blower capacity is too low, refer to the TROUBLESHOOTING CHECKLIST before contacting the nearest Roots sales office for recommendations.

Safety Precautions

When working with any of the equipment mentioned in this manual, it is important to observe safety precautions to reduce chance of injury. The following safety considerations are particularly important:

- The blower casing and associated piping or accessories may become hot enough to cause major skin burns on contact.
- Internal and external rotating parts of the blower and driving equipment can produce serious physical injuries. Do not reach into any opening in the blower while it is operating, or while subject to accidental starting. Cover external moving parts with adequate guards.
- Disconnect power before doing any work, and do not bypass or render inoperable any safety or protective devices.
- If the blower is operated while the piping is disconnected, place a strong, coarse screen over the inlet and avoid standing in the discharge air stream.
- Stay clear of open inlet piping (suction area) of pressure blowers, and the open discharge blast from vacuum blowers.
- Stay clear of the blast from pressure relief valves and the suction area of vacuum relief valves.
- Avoid extended exposure in close proximity to machinery that exceeds safe noise levels.
- Use proper care and good procedures in handling, lifting, installing, operating, and maintaining the equipment.

- Use proper care and good procedures in handling, lifting, installing, operating, and maintaining the equipment.
- Casing pressure must not exceed 25 PSI (172 kPa) gauge. Do not pressurize vented cavities from an external source. Do not restrict the vents.
- Do not use air blowers on explosive or hazardous gases.
- Other potential hazards to safety may be associated with operating this equipment. All personnel working in or passing through the area should be warned by signs and trained to exercise adequate general safety precautions.

Preventive Maintenance

Daily

- Record the following:
 - Lube oil pressure (if applicable)
 - Lube oil temperature (if applicable)
 - Blower inlet temperature
 - Blower inlet pressure
 - Blower discharge temperature
 - Blower discharge pressure or differential pressure
 - Motor amperage
 - Motor voltage, if available
 - Motor stator temperature, if available
 - Motor bearing temperature, if available
- Observe any abnormalities, such as burned paint, unusual noises, vibration, strange odors, oil leaks, and so on.
- Review log sheets to determine if there are any changes from previous readings. It is very important to look for any changes or trends that might indicate pending problems.
- Check oil levels.
- Record hour meter readings.

Monthly

Record bearing housing vibration levels at each bearing in the horizontal, vertical, and axial planes. Use velocity (inches per second) measurements and note any changes from previous readings. Take a complete vibration signature (amplitude versus frequency) if any trends are noted. It may be helpful to keep a chart noting monthly readings.

Quarterly

- Sample the lube oil
- Change the oil if the following values are exceeded:
 - Water 100 PPM maximum
 - Metals 200 PPM maximum
 - Acid 5.0 to 7.5 mg/KOH/g maximum
- Increase the sample frequency if any of the above values show a 20 to 25 percent increase over the last sample.
- Flush all oil reservoirs before filling with clean oil.
Annually
- Remove an inlet expansion joint, inspect the impellers, measure impeller clearances, and note wear patterns.
- Check the coupling alignment, inspect the coupling for wear, and repack with fresh grease.
- Inspect oil cooler tubes, as applicable.
- Check all protective switches for proper setpoints and operation.
- Check v-belt drive condition and tension.

Note: A preventative maintenance schedule should be established for drivers and all accessories in accordance with the applicable manufacturer's recommendation.

Troubleshooting Checklist

Trouble	Item	Possible Cause	Remedy
No flow	1	Speed too low	Check by tachometer and compare with published performance.
	2	Wrong rotation	
	3	Obstruction in piping	Compare actual rotation with Figure 1, change driver if wrong. Check piping, valves, silencer to assure open flow path.
Low capacity	4	Speed too low	See item 1, if belt drive, check for slippage and readjust tension. Check inlet vacuum and discharge pressure and compare with published performance.
	5	Excessive pressure rise	
	6	Obstruction in piping	See item 3. Check inside of casing for worn or eroded surfaces causing excessive clearances
	7		
Excessive power	8	Speed too high	Check speed and compare with published performance. See item 3
	9	Excessive pressure rise	
	10	Impeller rubbing	Inspect outside of cylinder for high temperature areas, then check for impeller contact at these points. Look for excessive scale build-up. Correct blower mounting, drive alignment.
Overheating of bearings or gears	11	Inadequate lubrication	Check oil sump levels in gearhouse and drive end covers
	12		
	13	Excessive lubrication	Check oil levels. If correct, drain and refill with oil of recommended grade. See item 5.
	14	Excessive pressure rise	Check carefully. Realign if questionable. Readjust for correct tension.
	15		
Vibration		Coupling misalignment	
		Excessive belt tension	
	16	Misalignment	See item 14
	17	Impellers rubbing	See item 10
	18	Worn bearings/gears	Check gear backlash and conditions of bearings and replace as indicated.
	19	Unbalanced or rubbing impeller	Scale or process material may build up on casing and impellers, or inside impellers. Remove build-up to restore original clearances and impeller balance.
20	Driver or blower loose	Tighten mounting bolts securely.	
21		Piping resonances	Determine whether standing wave pressure pulsations are present in the piping. Refer to Sales office.

Rotary Lobe Blower Vibrations

Blower vibration levels should be monitored on a regular basis. Take measurements at the bearing locations on the housings and refer to the chart below for guidelines on assessing the vibration severity of a rotary lobe blower rigidly mounted on a stiff foundation. When vibration measurements indicate that a review is required, the installation should be fully evaluated to determine and resolve the causes of vibration.

In addition, vibration level trends should be observed for progressive or sudden changes. If a change occurs, the cause should be determined through spectral analysis.

Blower vibrations are transmitted into the motor, speed reducer, and other system components. Make sure to obtain the allowable vibration levels of all accessories from the associated vendors.

Unfiltered Vibrations (in/sec peak)	Assessment
>0.62 thru 1.0	Satisfactory
>1.0	Review Required

Note: Rotary lobe blower vibrations are measured in inches per second. The measurement of spike energy is not recommended for judging blower condition because the rotary lobe blower has inherent impacting bearing loads.

The following items generate vibrations in rotary lobe blowers:

- Inherent rotary lobe blower characteristics can lead to vibrations:
 - Impacting bearing loads excite component/system natural frequencies.
 - Pressure pulsations set off vibrations at four times the running speed (RPM).
- Very close clearances between the impellers and the housing can result in vibrations set off by impeller contact:
 - Impeller to impeller frontal lobe contact. If contact is between only one set of lobes, the vibration frequency is one times the RPM. If both sets of lobes contact, the vibration frequency is two times the RPM.
 - Impeller to cylinder contact. The vibration frequency depends on the number of impeller tips contacting the cylinder and can range from one to four times the RPM.
 - Impeller to head plate contact. The vibration frequency is erratic and unsteady.
- Damaged gears generate vibrations at mesh frequency (number of teeth times RPM).
- Damaged bearings generate vibrations at ball pass frequency, fundamental train frequency, and ball spin frequency.
- Rotor unbalance and a bent shaft generate vibrations at one times RPM.

- Blower/driver coupling misalignment generates vibrations at one times RPM and two times RPM.
- Acoustic resonance in the blower inlet/discharge piping generates vibrations at four times RPM.
- Operation of a rotary lobe blower at or near system torsionals may cause impeller lobe contact and increase vibrations.
- If external piping is not properly isolated it will transmit vibrations into the blower.
- The foundation design and mounting method considerably affect blower vibrations.

Maintenance/Replacement

A consistent program of inspection and maintenance is the most reliable way to reduce the need for costly blower repairs. To help establish a regular maintenance schedule, keep a simple record of procedures and dates. While operating the unit within its specified rating limits is the best way to help ensure a satisfactory service life, the following basic ongoing service needs should also be performed:

- Lubrication
- Cleaning
- Checking for hot spots
- Checking for increases or changes in vibration
- Frequently observing inlet and discharge pressures to ensure that blower ratings are not exceeded

In a properly installed and operated blower, there is no moving contact between the two impellers, or between the impellers and cylinder or headplates. Wear is confined to the timing gears, the bearings that support and locate the shafts, and the shaft oil seals. When properly lubricated with clean oil of the correct grade, only normal wear should occur. Shaft seals (lip type or rotating mechanical type), are subject to deterioration as well as wear and may require replacement at varying periods. O-rings should be replaced at each disassembly.

Troubleshooting and Repairs

Refer to the TROUBLESHOOTING CHECKLIST for a wide range of causes and solutions for operating troubles.

Repairs not covered in this manual are considered beyond the scope of maintenance. Refer to the nearest Roots sales office as listed on the last page of this manual. Do not attempt to repair failures covered by warranty, unless specific approval has been obtained through a Roots sales office before starting the work. Unauthorized disassembly within the warranty period may void the warranty.

When repairs involve parts replacement, factory parts should be used to ensure fit and suitability. Keeping spare parts on hand can help reduce delays associated with repairs. Remember to supply all information from the blower nameplate when ordering parts.

Troubleshooting and Repairs

Repair Kit Information for RAS/RAS-J splash Lube Blowers 10"-20"

Ref.	Qty.	Description
17	1	SHIM SET
18	1	GASKET
19	2	GASKET SUMP (P/L)
20	4	O RING B/C (PL)
23	1	SEAL-DR. SHAFT
24	2	LOCKNUT-BRG.
25	2	LOCKWASHER-BRG.
27	4	SEAL-HDPLT
31	4	BEARINGS
60	1	BEARINGS *
61	2	O-RING
81	2	GASKETS
-	1 SET	GEAR SCREWS **

Repair Kit Information for RAS/RAS-J Splash Lube Blowers 10"-20"

Size	Repair Kit Nos. (CPLG Drive)	Repair Kit No. (V-Belt Drive)
10"	RK10ACP00	RK10AVB00
12"	RK12ACP00	RK12AVB00
14"	RK14ACP00	RK14AVB00
16"	RK16ACP00	
18"	RK18CP00	
20" (22 PSL)	RK20ACP00	
20" (40 PSL)	RK20ACP0040	

When ordering spare parts contact:

Roots Roots
900 West Mount Street
Connersville, IN 47331-1675

E-mail: Connersville.Customercare@Roots.com

Phone: +1-765-827-9200

Table 10 - Parts Identification List for Figures 17-20

Item Number	Quantity Used	Identification
1	1	Headplate - Gear End
1A	1	Headplate - Drive End
2	1	Cylinder
3	1	Gearbox
5	1	End Cover - Driving (Cplg.)
5A	1	End Cover - Driven Shaft
6	4a	Bearing Carrier
7	2	Impeller
9	2	Timing Gear
10	2	Timing Gear Locking Assembly
12	2	Stub Shaft - Gear End
13	1	Stub Shaft - Driving
14	1	Stub Shaft - Driven
15		
16	1	Key - Drive Sheave or Coupling
17	4 halves	Shims – Brng. Carrier, Drive End
18	1	Gasket - Gearbox Flange
22	Varies	Capscrew - End Cover (Soc. Hd.)
23	1	Shaft Seal - Outboard
24	2	Bearing Locknut
25	2	Bearing Lockwasher
26	8	Lockwasher - Brng. Carrier (See 49)
27	4	Shaft Seal - Inboard
28	2	Air Vent - Drive End
29	2	Eyebolt - Lifting
30	Varies	Capscrew - Gearbox & Headplate Fig.
31	4	Bearing - Roller
34	1	Nameplate
35	6	Drive Screw - Nameplate & Arrow
36	8 or 0d	Dowel Pin - Flange Locating
37	1	Vent Plug - Gearbox
42	Varies	Capscrew - Stub Shaft (Soc. Hd.)
43	Varies	Taper Pin - Stub Shaft, Gear End
45		
49	16	Capscrew - Brng. Carrier (See 26)
56	1	Rotation Arrow
58	1	End Cover - Driving (Belted)

Item Number	Quantity Used	Identification
60	1	Bearing - Inboard (f)
61	2	O-ring - End Cover
62	1	Spacer Sleeve - Outboard Brng.
63	1	Bearing Carrier - Extended Drive
64	2	Dowel Pin - End Cover
66	1	Air Vent - End Cover (Belted)
67	1	Plug - Gearbox Drain
69	4	Plug - Bearing Housing
70	4	Plug - Instrument Taps
71	2	Leveling Label
72	4	Set Screw - Leveling
73		
74		
75		
76		
77	1 or 2c	Spacer Ring - Drive End Bearing
78		
80		
81	2	Gasket - Brng. Carrier, Gear End
82	2	Oil Dam - Gear End Bearing
83	2	Oil Control Shield
84	1 or 2b	Oil Pan (Secondary Sump)
85	4	Capscrew - Oil Pan
86	Varies	Self-Tap Screw - Oil Pan
87	1	Gauge Oil Level - Gear End
88	6	Plug - Drive end Fill & Drain
89	2	Locking Nut (See 96)
90	2	Gauge Oil Level - Drive End
91		
92	1	Lube Nameplate - Gear End
93	1	Lube Nameplate - Drive Enc
94		
95		
96	2	Slinger Set Screw (See 89)
100	4 or 0d	Dowel Pin - Flange Locating
110	1 or 0e	Oil Shroud
111	1 or 0e	Oil Shield

- a. All units having extended shaft for belt drive, use three item 6 and one item 63.
- b. Vertical style units, use one item 84. Horizontal units, require two item 84.
- c. Used on sized 1000 through 1400 only.
- d. Units of frame sizes 1000 through 1400 except 1442 use four item 100. Frames 1600 through 2000 and 1442 use eight item 36.
- e. Vertical style units use one item 110 and one item 111. Not required on horizontal units.
- f. Inboard bearing item 60 is a double row spherical type on current production units, and the cylindrical roller bearing on older units will be replaced with the new spherical roller bearing.

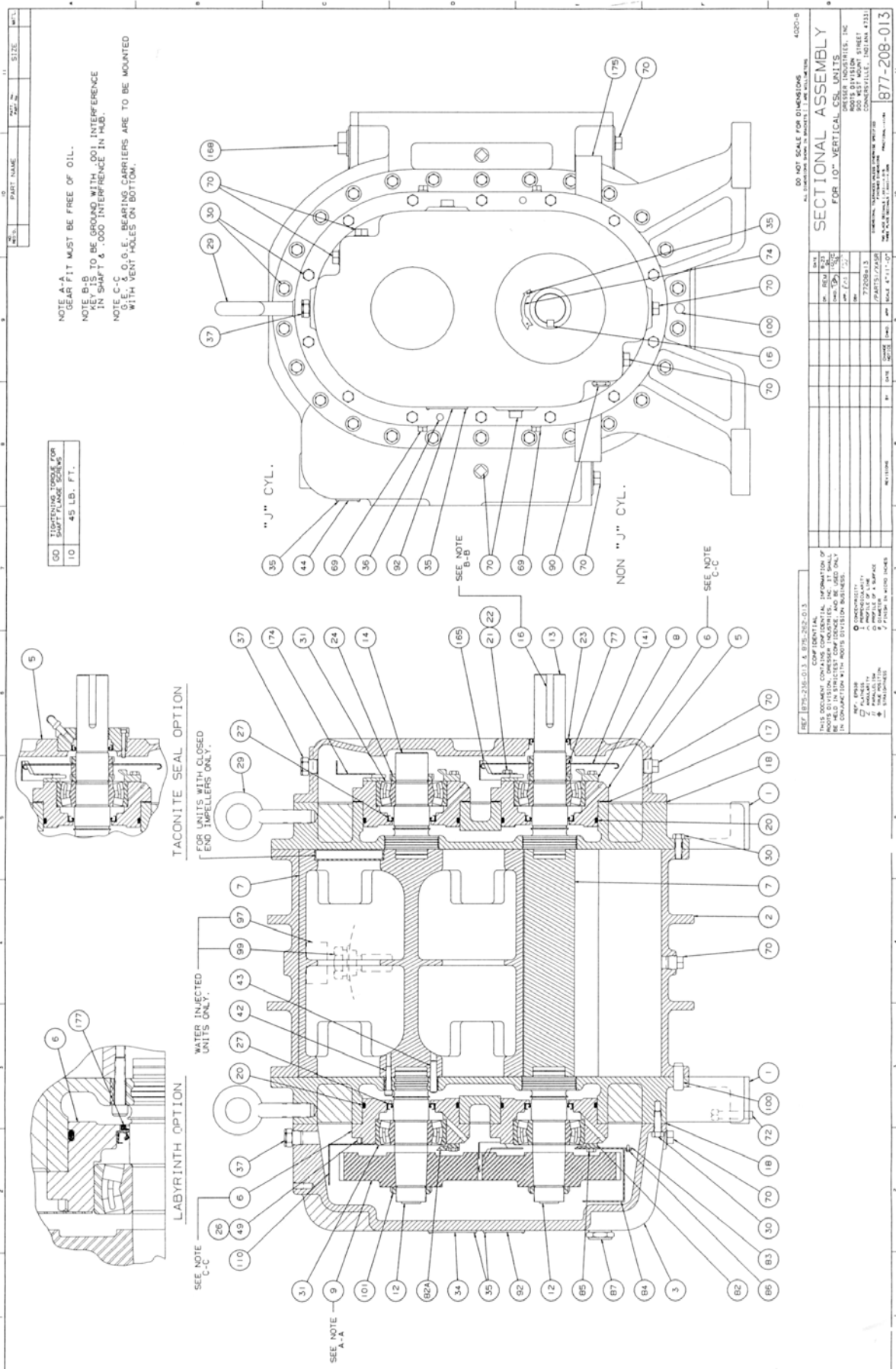

Figure 17 - Assembly of Basic 10" Vertical CSL Style Blower

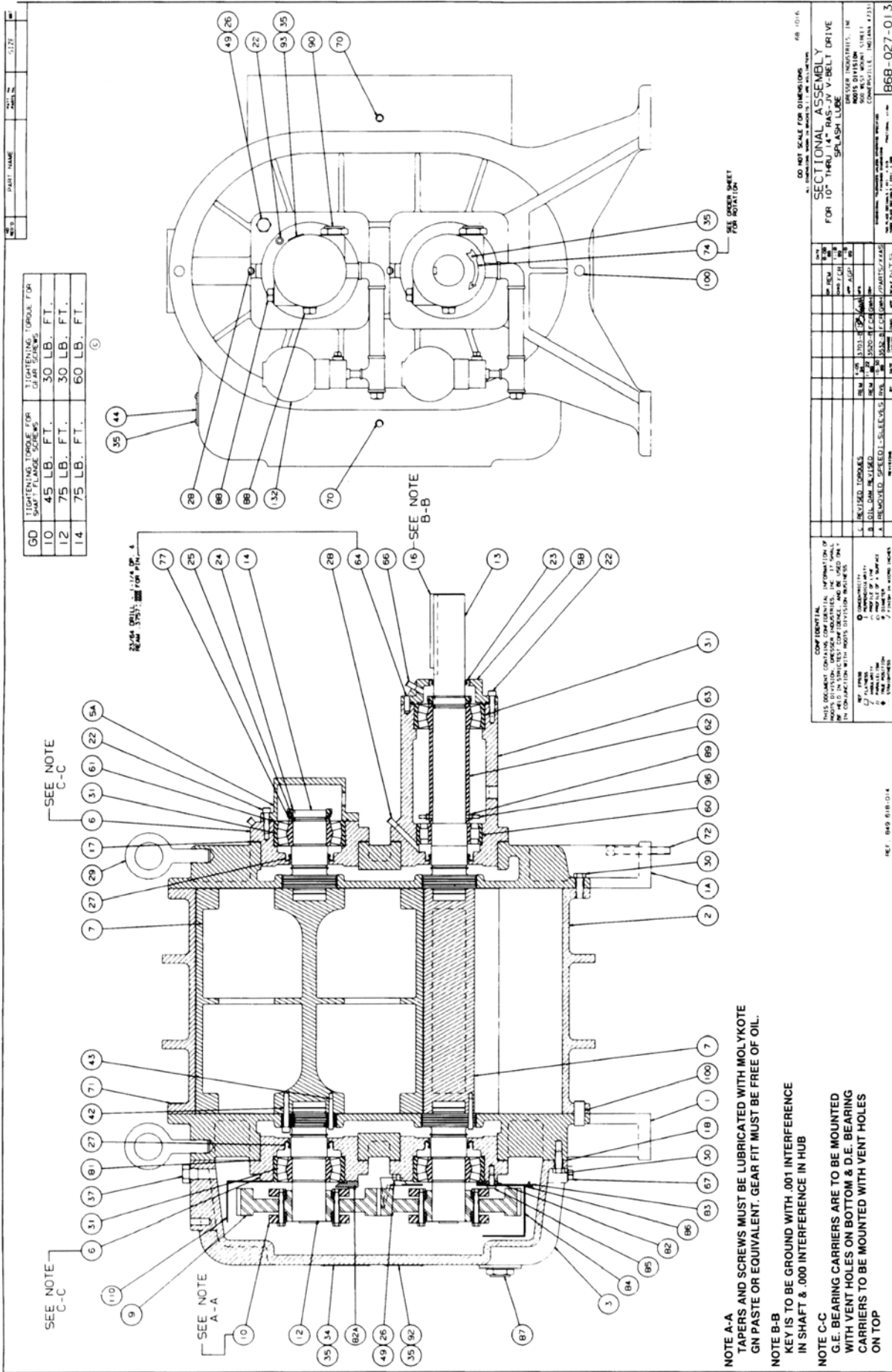

Figure 18 - Assembly of RAS WHISPAIR™ Vertical Style Blower

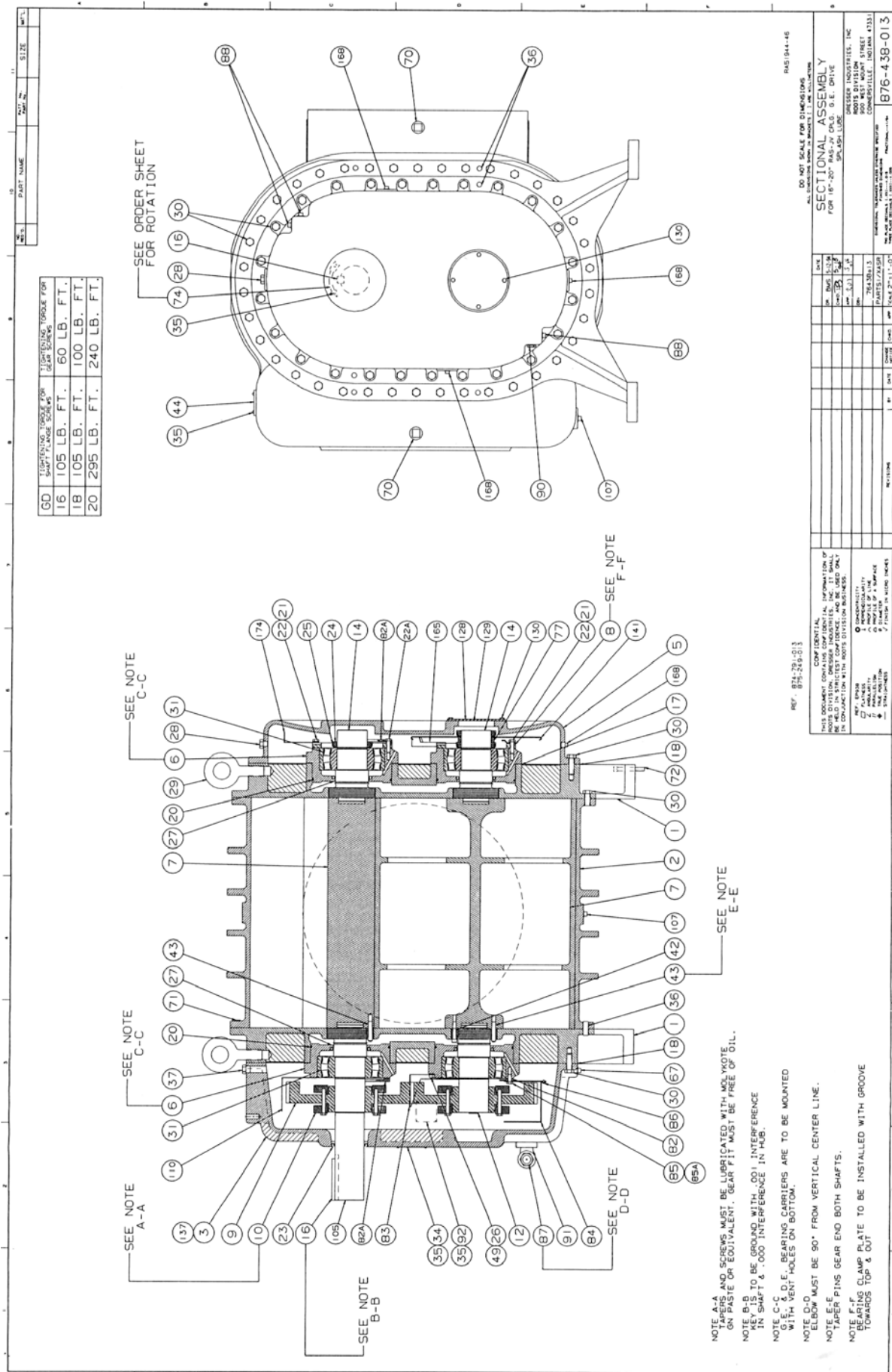

Figure 19 - Assembly of RAS WHISPAIR™ Vertical Style Blower

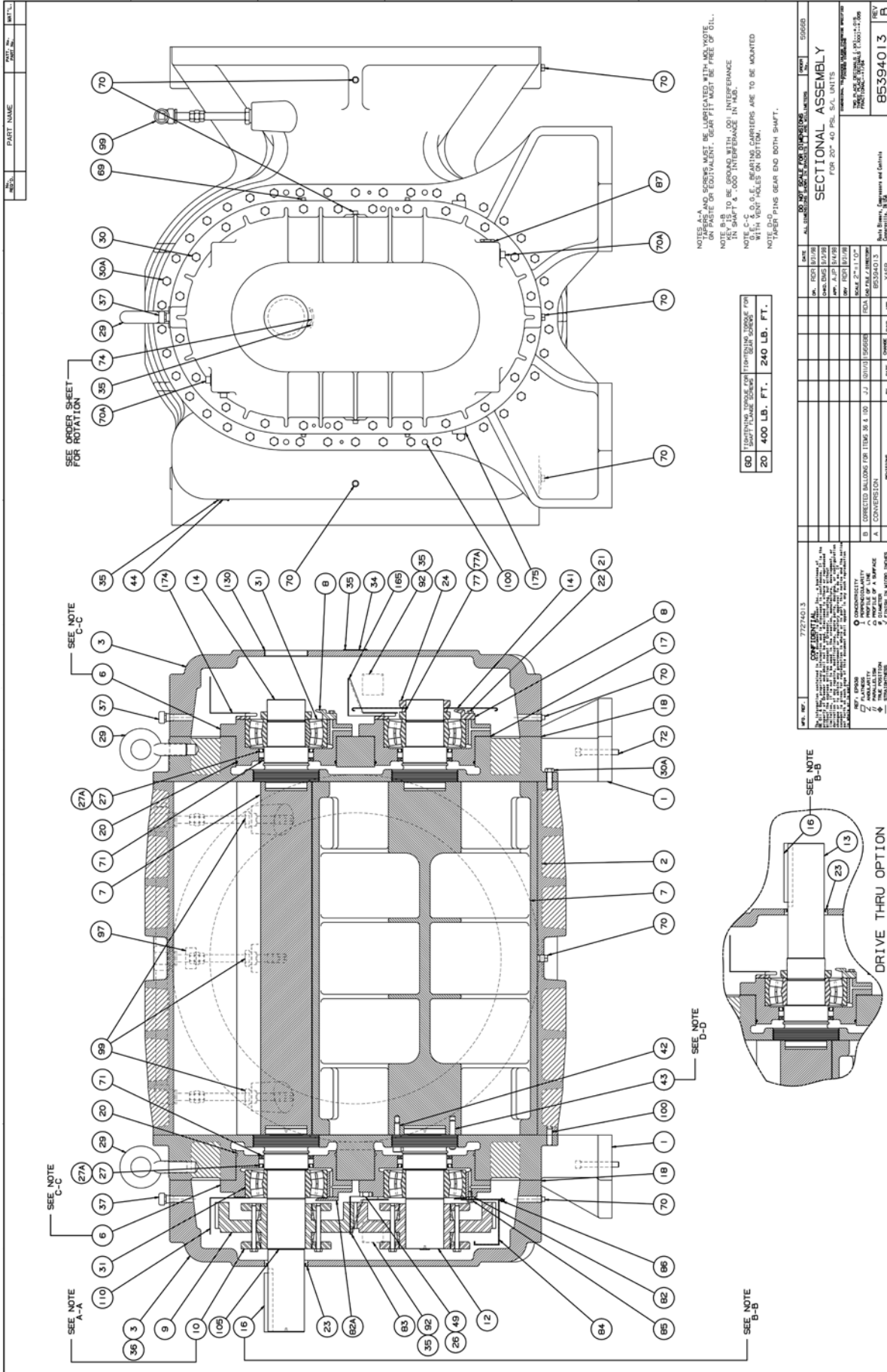

Figure 20 - Assembly of 20" RAS / RAS-J (40 PSL)



900 W. Mount St. Connersville
Indiana, 47331, USA



BLOWERS. ACCESSORIES. PARTS. DESIGN. FABRICATION. SERVICE.

1-800-536-9933 | customerservice@pdblowers.com

Find us online at PDBLOWERS.COM